

Chapter 14 - REFUND



CA Vishal Bhattad

Refund-Procedure-1

[General Procedure]

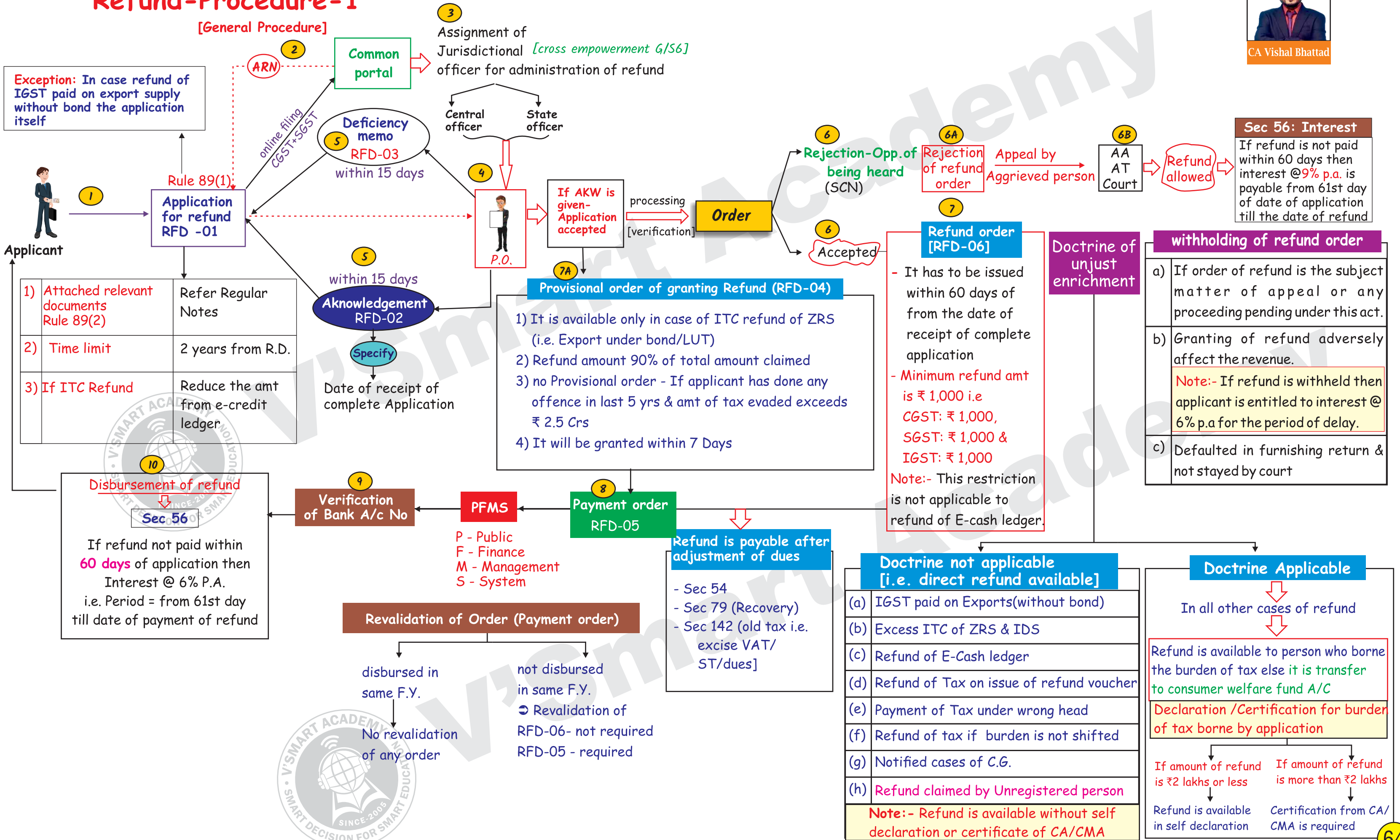

Exception: In case refund of IGST paid on export supply without bond the application itself



1) Attached relevant documents Rule 89(2)	Refer Regular Notes
2) Time limit	2 years from R.D.
3) If ITC Refund	Reduce the amt from e-credit ledger

7A Provisional order of granting Refund (RFD-04)

- 1) It is available only in case of ITC refund of ZRS (i.e. Export under bond/LUT)
- 2) Refund amount 90% of total amount claimed
- 3) no Provisional order - If applicant has done any offence in last 5 yrs & amt of tax evaded exceeds ₹ 2.5 Crs
- 4) It will be granted within 7 Days

7 Refund order [RFD-06]

- It has to be issued within 60 days of from the date of receipt of complete application
- Minimum refund amt is ₹ 1,000 i.e. CGST: ₹ 1,000, SGST: ₹ 1,000 & IGST: ₹ 1,000
- Note:- This restriction is not applicable to refund of E-cash ledger.

Doctrine of unjust enrichment

withholding of refund order

a)	If order of refund is the subject matter of appeal or any proceeding pending under this act.
b)	Granting of refund adversely affect the revenue. Note:- If refund is withheld then applicant is entitled to interest @ 6% p.a for the period of delay.
c)	Defaulted in furnishing return & not stayed by court

10 Disbursement of refund

Sec 56

If refund not paid within **60 days** of application then Interest @ 6% P.A. i.e. Period = from 61st day till date of payment of refund

8 Payment order RFD-05

Refund is payable after adjustment of dues

- Sec 54
- Sec 79 (Recovery)
- Sec 142 (old tax i.e. excise VAT/ST/dues]

9 Verification of Bank A/c No → PFMS

Revalidation of Order (Payment order)

- disbursed in same F.Y. → No revalidation of any order
- not disbursed in same F.Y. → Revalidation of RFD-06 - not required, RFD-05 - required

Doctrine not applicable [i.e. direct refund available]

(a)	IGST paid on Exports(without bond)
(b)	Excess ITC of ZRS & IDS
(c)	Refund of E-Cash ledger
(d)	Refund of Tax on issue of refund voucher
(e)	Payment of Tax under wrong head
(f)	Refund of tax if burden is not shifted
(g)	Notified cases of C.G.
(h)	Refund claimed by Unregistered person

Note:- Refund is available without self declaration or certificate of CA/CMA

Doctrine Applicable

In all other cases of refund

Refund is available to person who borne the burden of tax else it is transfer to consumer welfare fund A/C

Declaration / Certification for burden of tax borne by application

If amount of refund is ₹2 lakhs or less	If amount of refund is more than ₹2 lakhs
Refund is available in self declaration	Certification from CA/CMA is required



Refund of ITC

ZRS With bond/LUT [Sec 16(3)(a) & Rule 89(4)]	Max time limit for application	Relevant Date	Doctrine of Unjust Enrichment	Application Form	Amount of Refund	Documents & Conditions												
	2 Years from Relevant Date (RP may claim at the end of any tax period)	the due date for furnishing of return under section 39 in respect of such supplies	NA	RFD-01	Maximum refund (As per formula refer Below)	Statement containing No. & date of Invoice along with such other notified particulars												
	<p>Without payment of tax under Bond/LUT Outward Supply</p> <p>Supplier</p> <p>CG → ITC can be claimed if not utilised then C/F</p> <p>I</p> <p>IS</p> <p>But refund of ITC u/s 54(3) read with rule 89(4) is not allowed</p> <p>Option-1: availed the ITC of I + IS & used it for output tax if any or Option-2: Excess ITC of I + IS exclusive used in ZRS (under Bond) - Refund allowed as per rule 89(4)</p> <p>Export</p> <p>ZRS</p> <p>Undertake Bond or LUT</p> <p>Export of G/S without tax [refer Rule 96A]</p>		<p>C. Turnover of zero-rated supply of Services (ZRSS)</p> <p>means the value of zero-rated supply of services made without payment of tax under bond or LUT, calculated in the following manner, namely:-</p> <table border="1"> <thead> <tr> <th>Particular</th> <th>Amount</th> </tr> </thead> <tbody> <tr> <td>payments received during the relevant period for ZRSS</td> <td>XXX</td> </tr> <tr> <td>Add: ZRSS where advance has been received in prior period but supply has been completed in relevant period</td> <td>XXX</td> </tr> <tr> <td>Less: advances received in relevant period for which supply of services has not been completed</td> <td>XXX</td> </tr> <tr> <td>T.O of ZRSS</td> <td>XXX</td> </tr> </tbody> </table>		Particular	Amount	payments received during the relevant period for ZRSS	XXX	Add: ZRSS where advance has been received in prior period but supply has been completed in relevant period	XXX	Less: advances received in relevant period for which supply of services has not been completed	XXX	T.O of ZRSS	XXX	<p>D. Adjusted Total turnover"</p> <p>SOG: T/o in State includes</p> <ul style="list-style-type: none"> ⇒ All Taxable Supply, Wholly Exempt Supply [WE + Nil + NTS] ⇒ Exports supply (with or without bond) ⇒ Inter State Supply <p>excludes taxes under GST & Inward supplies under RCM</p> <p>SOS:</p> <p>Zero Rated Supply of services (ZRSS) (As calculated above)</p> <p>Add: Non ZRS of Services (Domestic supply + Export without Bond)</p> <p>Less:</p> <p>1) Exempt Supplies other than Zero rated Supplies* (xx)</p> <p>2) T/o of supplies for which refund is claimed u/r 89(4A) or (4B) or both (xx)</p> <p>Adjusted Total T/o (xx)</p> <p>Notes:</p> <ul style="list-style-type: none"> ⇒ Exempt supplies & T/o of supplied for refund is claimed u/r 89(4A)/89(4B) is deducted only if already covered in T/o of ZRS of goods or services. ⇒ Other than ZRS*: As per Sec 16 of the IGST Act, if an exempt supply is exported from India, it is not considered an exempt supply and falls under ZRS. Therefore, any exempt supply that qualifies as ZRS should not be deducted. 			
Particular	Amount																	
payments received during the relevant period for ZRSS	XXX																	
Add: ZRSS where advance has been received in prior period but supply has been completed in relevant period	XXX																	
Less: advances received in relevant period for which supply of services has not been completed	XXX																	
T.O of ZRSS	XXX																	
	$\text{Refund Amount} = \frac{\text{Turnover of Zero rated supply of goods} + \text{Zero rated supply of services}}{\text{Adjusted total Turnover}} \times \text{Net ITC}$																	
	<p>Non- eligibility of Refund :-</p> <p>1) Export goods are liable to export duty 2) Drawback claimed for GST</p> <p>Cir. No. 160/16/2021 :- Export goods are Nil rate or exempt is not treated as subject to export duty & Refund is available</p>																	
	<table border="1"> <thead> <tr> <th>A. Net ITC</th> <th>Particular</th> <th>Amount</th> </tr> </thead> <tbody> <tr> <td></td> <td>Total ITC of (I + IS) in relevant period</td> <td>XXX</td> </tr> <tr> <td></td> <td>Less: ITC of Inputs for which refund is claimed u/r 89(4A) & 89(4B)</td> <td>XXX</td> </tr> <tr> <td></td> <td>Net ITC</td> <td>XXX</td> </tr> </tbody> </table> <p>Note:- Only ITC of I & IS shall be considered & no ITC of CG</p>		A. Net ITC	Particular	Amount		Total ITC of (I + IS) in relevant period	XXX		Less: ITC of Inputs for which refund is claimed u/r 89(4A) & 89(4B)	XXX		Net ITC	XXX				
A. Net ITC	Particular	Amount																
	Total ITC of (I + IS) in relevant period	XXX																
	Less: ITC of Inputs for which refund is claimed u/r 89(4A) & 89(4B)	XXX																
	Net ITC	XXX																
	<p>B. Turnover of ZRS of goods</p> <p>Means the actual value of ZRS (lower of FOB value in shipping bill or value in invoice) exported under bond/LUT OR 1.5 times like goods domestically supplied in a relevant period</p> <p>Whichever is Lower</p> <table border="1"> <tbody> <tr> <td>Value of ZRSG</td> <td>XX</td> </tr> <tr> <td>Less: T/o of supplies for which refund is claimed u/r 89(4A)/(4B)</td> <td>(XX)</td> </tr> <tr> <td>T/O of ZRS of goods</td> <td>XX</td> </tr> </tbody> </table>		Value of ZRSG	XX	Less: T/o of supplies for which refund is claimed u/r 89(4A)/(4B)	(XX)	T/O of ZRS of goods	XX	<p>E. Relevant period</p> <p>means the period for which the claim has been filed.</p>									
Value of ZRSG	XX																	
Less: T/o of supplies for which refund is claimed u/r 89(4A)/(4B)	(XX)																	
T/O of ZRS of goods	XX																	

Inverted Duty Structure (IDS) Rule 89(5)

Max time limit for application	Relevant Date	Doctrine of Unjust Enrichment	Application Form	Amount of Refund	Documents & Conditions
2 Years from Relevant Date (RP may claim at the end of any tax period)	D/D of furnishing return u/s 39, for the period in which such claim for refund arises	NA	RFD-01	Maximum refund by formula (Notes)	Statement containing No. & date of Invoice received / issued during tax period

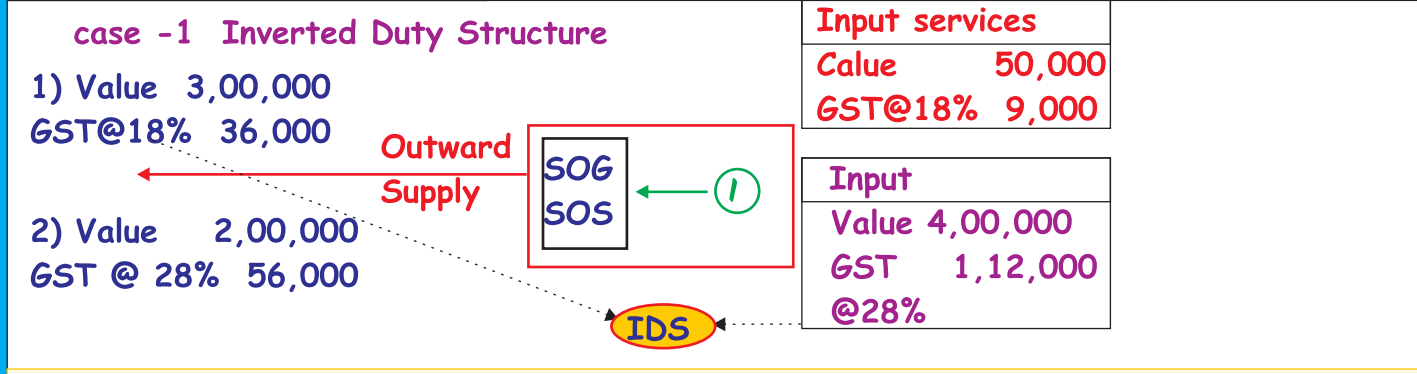

$$\text{Maximum Refund Amount} = \left[\frac{\text{T/o of inverted rated supply of goods and services}}{\text{Adjusted Total T/O}} \times \text{Net ITC} \right] - \left[\text{Tax payable on such inverted rated supply of goods and services} \right] \times \frac{\text{Net ITC}}{\text{ITC availed on I + IS}}$$

Non-eligibility of refund : 1) a) Construction sector. b) woven, knitted or crocheted fabrics c) Rail locomotives d) Oils, coal, lignite, peat etc. 2) If outward supply is exempt or nil rate (not the case of IDS)

A. Refund amount	means the maximum refund that is admissible	
B. Net ITC	Particular	Amount
	Total ITC of Inputs (only) in relevant period	XXX
	Less: ITC of Inputs for which refund is claimed u/r 89(4A) & 89(4B)	XXX
	Net ITC	XXX
	Note:- Only ITC of Input shall be considered here for refund & no refund of ITC of C.G. & IS	
C. Adjusted Total turnover	<p>SOG: T/o in State includes</p> <ul style="list-style-type: none"> All Taxable Supply, Wholly Exempt Supply, Non-Taxable Supply Exempt Supply (Wholly Exempt + Nil + NTS) Exports with or without bond Inter State Supply <p>excludes tax under GST & Inward supplies under RCM</p>	xx
	<p>SOS: Zero Rated Supply of services (As calculated above)</p> <p>Add: Non ZRS of Services (Domestic supply + Export without Bond)</p>	xx
	Less: 1) Exempt Supplies other than Zero rated Supplies*	(xx)
	2) T/o of supplies for which refund is claimed u/r 89(4A) or (4B) or both	(xx)
	Adjusted Total T/O	xx

Notes:

- Exempt supplies & T/o of supplied for refund is claimed u/r 89(4A)/89(4B) is deducted only if already covered in T/o of ZRS of goods or services.
- Other than ZRS*: As per Sec 16 of the IGST Act, if an exempt supply is exported from India, it is not considered an exempt supply and falls under ZRS. Therefore, any exempt supply that qualifies as ZRS should not be deducted.

D. Relevant period means the period for which the claim has been filed.

Clarification 125/44/19

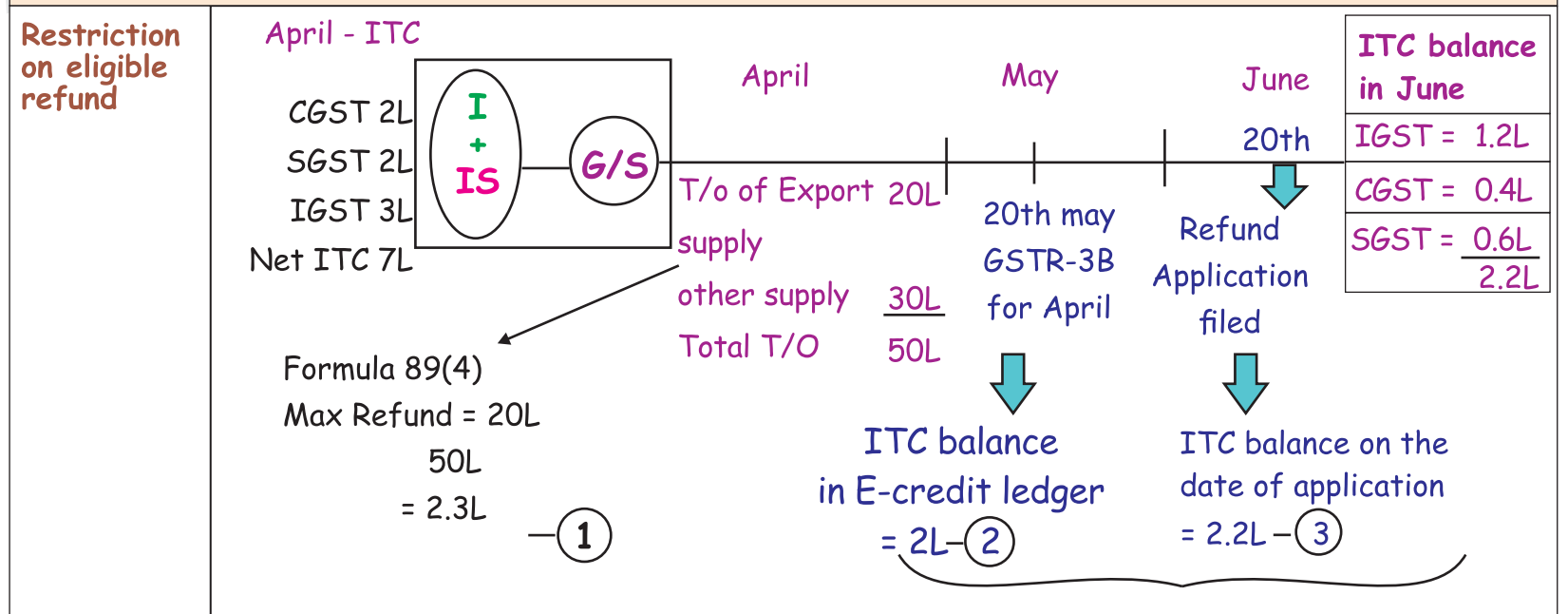

ITC balance in June	Amt. Debited	ITC CIF
IGST = 1.2L 1st Used	1.2L	Nil
CGST = 0.4L equally (50%)	0.4L	Nil
SGST = 0.6L equally (50%)	0.4L	0.2L
2.2L	2L	0.2L

Circular No.135/05/2020:

- Refunds of accumulated ITC are not allowed if the input & output supplies are the same, even if they have different tax rates.
- If the output tax rate is lower than the input tax rate, the accumulated credit can be refunded, except if the output supply is nil-rated, fully exempt, or specifically excluded by the Govt.

Deemed Export	Max time limit for application	Relevant Date	Doctrine of Unjust Enrichment	Application Form	Amount of Refund	Documents & Conditions
	2 Years from Relevant Date	Date on which return relating to such deemed export is furnished by supplier	Applicable	RFD-01	GST Paid	Statement containing No. & date of Invoice along with such other notified particulars

Person [Exporter]

Supplier Claiming Refund

Rule 89(4A) is Applicable & Refund allowed on Following Conditions

- 1) Documentary evidence- Statement Containing No. & date of Invoice
- 2) Undertaking by Recipient that he has not claimed ITC & Refund of such supply

Meaning:-

Sec. 2(39)- Deemed Exports- means supplies of goods notified u/s 147.
Sec 147= Govt notifies certain supplies as deemed export, where- Goods do not leave India, & manufactured in India, & Payment received in Indian rupees/ convertible foreign exchange.

Notified Supplies

Supplies notified as Deemed export are as follows:- i) Supply of Goods by RP against **Advance Authorisation**, ii) Supply of CG by RP against **EPCG Authorisation**, iii) Supply of goods by RP to **EOU**, iv) Supply of Gold by **Bank/PSUs** against **Advance Authorisation**.

Person Eligible to Claim Refund

- ➔ Recipient (Notified person i.e. AA, EPCG, EOU)
- ➔ Supplier (if recipient doesnot avail ITC & also furnishes undertaking that supplier may claim the refund)

Documents and Evidences

Refund To Supplier	OR Refund To Recipient
Documents :- statement containing number/date of invoices along with other notified evidences Evidences :- ➔ Acknowledgment by the Jurisdictional Tax officer of Advance Authorization / EPCG authorization holders ➔ Copy of tax invoices, duly signed by recipient ➔ Undertaking by recipient (that ITC not availed on such supplies) ➔ Undertaking by recipient (that shall not claim refund on such supplies & supplier may claim refund)	Documents :- ➔ Undertaking by supplier ➔ Filed by recipient ➔ Recipient shall not claim refund, to be furnished manually

Circular No. 172/04/2022-GST dt 06/07/2022]

- ➔ The ITC on deemed export supplies is not classified as ITC under the CGST Act.
- ➔ This means recipients can claim a refund for the full amount paid, regardless of any restrictions in section 17(5).

Important Note :- If refund is claimed Rule 89(4A) then it shall not be considered for calculation. "Net ITC" (For Recipient) or Export T/o & Adjusted T/O (For Supplier) under Rule 89(4) [Refund of ITC for IRS] & Rule 89(5) [Refund of ITC in case of Inverted tax structure]

Merchant Exporter (Penultimate Supply)	Max time limit for application	Relevant Date	Doctrine of Unjust Enrichment	Application Form	Amount of Refund	Documents & Conditions
	2 Years from Relevant Date	Date of receipt of goods	NA	RFD-01	CGST 0.05% SGST 0.05% IGST 0.1%	Refer Below

Supplier can claim refund of accumulated ITC under inverted tax structure

Concept- IGST @ 0.1% (CGST - 0.05% and SGST - 0.05%) on Inter-State/Intra State supply of taxable goods by Reg. supplier to Reg. recipient for export. Excess tax has been exempted by CG.

Conditions:- i) Reg. supplier Supply the goods to Reg. recipient (ME) on a tax invoice, ii) ME shall export goods within 90days from date of issue of tax invoice by Reg. supplier, iii) ME shall indicate GSTIN of supplier & tax invoice number on Shipping bill/Bill of export, iv) ME must be registered with Export Promotion Council/ Recognized Commodity Board v) Copy of purchase order to Jurisdictional officer of supplier, vi) Proof of export to be given to supplier & his jurisdictional officer vi) Full Rate applicable if goods not exported within 90days from date of invoice.

Supply of goods to SEZ Developer/ unit (ZRS)	Max time limit for application	Relevant Date	Doctrine of Unjust Enrichment	Application Form	Amount of Refund	Documents & Conditions	
	2 Years from Relevant Date	the due date for furnishing of return u/s 39 in respect of such supplies	Applicable in certain cases	RFD-01	IGST paid	SOG	<ul style="list-style-type: none"> Statement containing the number & date of invoice evidence regarding goods admitted in full for authorized operations as endorsed by the specified officers of SEZ
	Comment :- In case of supplies made to SEZ unit or developer of SEZ (a) supplier of goods after such goods have been admitted in full in the SEZ for authorised operations, as endorsed by the specified officer of the Zone. (b) supplier of services along with such evidence regarding receipt of services for authorised operations as endorsed by the specified officer of SEZ [Second proviso to rule 89(1)].					SOS	<ul style="list-style-type: none"> Statement containing the number & date of invoice evidence regarding receipt of services for authorized operations as endorsed by the specified officer of SEZ, the details of payment, along with proof there of made by the recipient to supplier for authorised operation.
						SOG & SOS	a declaration to the effect that tax has not been collected from the SEZ unit or the SEZ developer"

Person Holding UIN (Rule 95)	Max time limit for application	Relevant Date	Doctrine of Unjust Enrichment	Application Form	Amount of Refund	Documents & Conditions
	Application once in every Qtr, but before expiry of 2 years, from last Qtr of supply received	Date of Payment	NA	GSTR-11	Tax paid on purchases of Goods/service	Details of Purchase Invoice
<p>Rule 95</p> <ul style="list-style-type: none"> Refunds can be claimed by: <ul style="list-style-type: none"> Specialized agencies of the UNO Multilateral Financial Institutions under the UN Privileges Act Foreign consulates or embassies Other specified persons or classes. Time Limit for Filing Refund Claims: Once in every quarter, within 2 years from the last day of the quarter when the supply was received. Applications must be in Form GSTR-11. Conditions for Refund Approval: Refunds will be granted if: <ul style="list-style-type: none"> Inward supplies were received against a tax invoice from a registered person. The applicant's name and GSTIN/UIN are on the invoice. If the UIN is missing, the invoice must be attested by an authorized representative. All other notified conditions are met. Refund of IGST on Imported Goods: Specialized agencies can claim refunds of IGST paid on imported goods, as the IGST rate for imports aligns with that of domestic supplies. Supremacy provision in case of inconsistency: If a treaty/ international agreement, to which the President / Govt. of India is a party, is inconsistent with Rule-95, Such treaty/international agreement shall prevail. 						

Refund In Other Cases

	Procedure	Max.time limit for application	Relevant Date	Doctrine of Unjust Enrichment	Application Form	Amount of Refund	Documents & Conditions
Balance of E cash Ledger	Direct refund in Return	RP can also claim refund in tax period also in GSTR 3/3B	Date of payment of tax	NA		Excess Bal. in E-cash ledger	-

Important points clarified by CBIC:- 1) time period, refund application u/s 54(1), is not applicable in cases of refund of excess balance in E-Cash ledger 2) certification/ declaration for not passing the incidence of tax to any other person is not required to be furnished along with the application for refund of excess balance in E-Cash ledger 3) refund of TDS/TCS deposited in electronic cash ledger can be refunded as excess balance in cash ledger

E cash ledger refund to CTP/NRTP	Direct refund in Return	2 Years from Relevant Date	Refund, only after filing return of entire period for which registration is held (i.e. only after filing last return of CTP/NRTP)	NA	RFD-01	Amount paid extra in advance after filling return	Final return by CTP/NRTP
Order of Court/ Tribunal	R. Procedure-(1)	2 Years from Relevant Date	Date of communication of judgement/ decree/ order/direction	Applicable	RFD-01	Amount specified in order	Reference No. of order, Copy of order
Finalisation of Provisional Assessment	R. Procedure-(1)	2 Years from Relevant Date	Date of final assessment	Applicable	RFD-01	Difference of provisional tax and final tax	Reference No. of Final assessment order, Copy of said order
Wrong Payment of tax	R. Procedure-(1)	2 Years from Relevant Date	Date of payment	NA	RFD-01	Amount wrongly paid	St. showing details of transactions considered as Intra state supply, but which subsequently held inter state supply or vice versa
Excess payment of tax, Interest or any other amount paid	R. Procedure-(1)	2 Years from Relevant Date	Date of payment (But if recipient is eligible for refund, then date of receipt of goods/services)	Applicable	RFD-01	Excess amount paid	Statement showing the details of the amount of such Claim.

For Self Study

Export (Zero rated Supply)/ Deemed Export/Merchant Exporter/SEZ

Export without Bond/LUT	Max time limit for application	Relevant Date (i.e. Application of refund shall be filed within 2 years of following date)	Doctrine of Unjust Enrichment	Application Form	Amount of Refund	Documents & Conditions
Supply of Goods <i>(Procedure-2 is applicable)</i>	2 Years from Relevant Date	SOG exported by- (1) Sea/Air - ship/aircraft leaves India, (2) Land - Goods pass the frontier (3) Post - Dispatch of Goods	NA (Direct refund available & amount not credited to consumer welfare fund)	SOG- Shipping Bill	IGST Paid on outward supply (including ITC used for payment of IGST)	1) SOG- other than electricity 1) Statement containing No. & date of Shipping bill/Bill of export, 2) Date of relevant export invoices
Supply of Services <i>(Procedure-1 is applicable)</i>		SOS- (1) Amt received after supply = Date of receipt of CFC/Indian rupees(permitted by RBI), (2) Advance received - Date of invoice		SOS- RFD-01		2) SOS - 1) Statement containing No. & 2) date of invoice, 3) Relevant Bank realization certificate/ foreign inward remittance certificates 3) SOG - Export of electricity ⇒ Statement containing the no. & date of export invoice ⇒ details of energy exported, tariff per unit for export of electricity ⇒ copy of statement of scheduled energy for exported electricity by regional energy account Copy of agreement detailing the tariff per unit
Supply of Goods <i>(On Accounts of Additional IGST Paid on Export)</i>		SOG exported by- (1) Sea/Air - ship/aircraft leaves India, (2) Land - Goods pass the frontier (3) Post - Dispatch of Goods		SOG- RFD-01		⇒ Copies of export invoices and shipping bills/bill of export with numbers and dates. ⇒ Copies of bank realization or foreign inward remittance certificates, with numbers and dates. ⇒ Details of any refunds previously granted u/r 96. ⇒ Copies and dates of any relevant invoices or debit notes. ⇒ Proof of additional IGST payment and any interest. ⇒ Foreign inward remittance certificate for the additional payment, along with a CA/CMA certificate confirming the remittance is due to the price increase. ⇒ Copies of contracts or documents supporting the price revision.

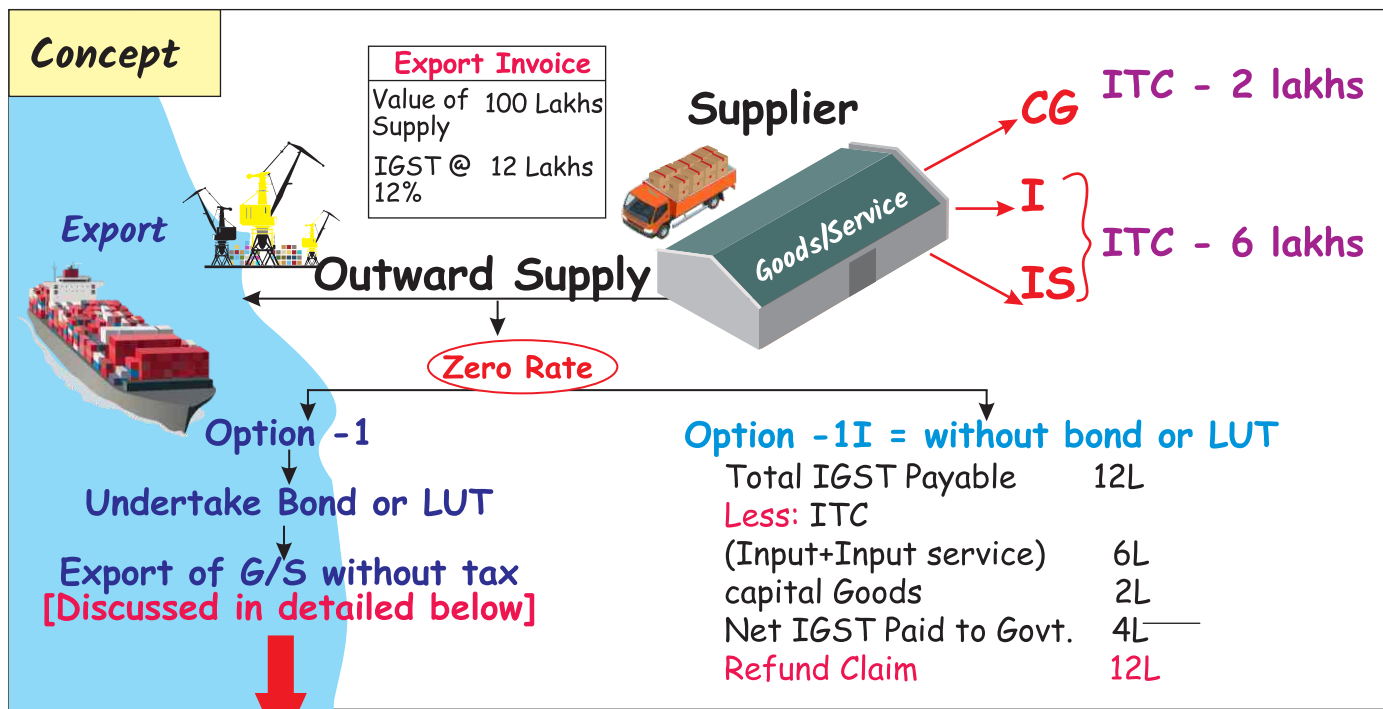

Note:- If supply is made without bond (i.e. after payment of IGST) no refund of ITC is available under rule 89(4)

Let's discussed here indetails

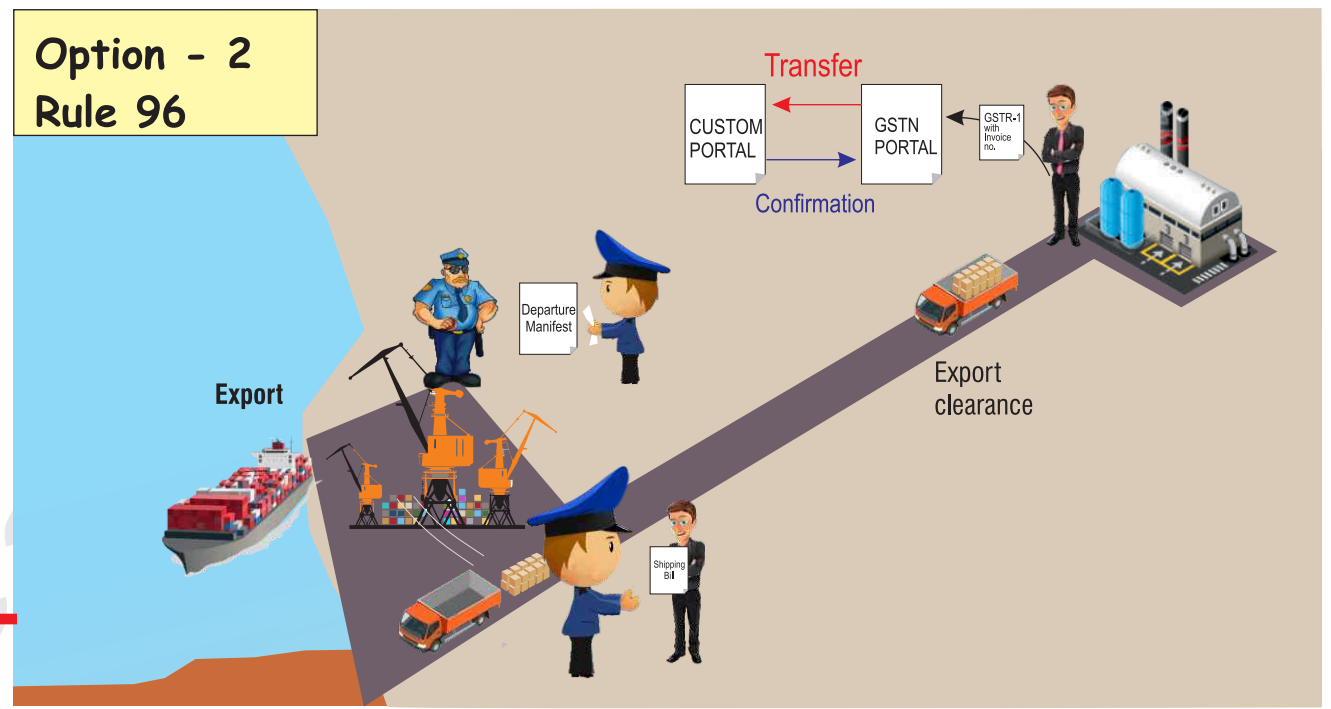

Rule 96A :- Export of Goods/ services under Bond/LUT

- Time limit: An RP shall furnish a bond/LUT in prescribed form, (binding to pay tax + Int @18%p.a)
 - a) SOG (Goods not exported): Pay taxes within 15 days after 3 months or any extended period allowed by the Commissioner.
 - b) SOS (Payment for services not received): Pay taxes within 15 days after 1 year or as allowed under FEMA including extension, from the invoice date.
- Electronic Transmission: Export invoices must be sent electronically in GSTR-1/GSTR-1A to the Customs portal for confirmation of export.
- Recovery: If goods aren't exported on time and the amount isn't paid, the bond/LUT will be withdrawn, and recovery will follow as per sec 79.
- Supply to SEZ: ZRS of goods/services to SEZ developers/units follow the same procedures as Rule 96A(1), without IGST payment.

Cir. No. 197/09/2023 :

- Exporters can claim a refund of unutilized ITC u/s 54(3) after exports or service payments.
- They can also refund IGST for goods not exported or unpaid services.
- No refund for interest paid is allowed.

Rule 96: Refund of IGST on goods/services exported out of India

- SOG:**
- Application:** The shipping bill is a refund application for IGST on exported goods when:
 - The person in charge files a departure manifest covering the shipping bill details.
 - The applicant submits a valid GSTR-3B return. If there's a mismatch between the shipping bill data & GSTR-1, the application is deemed filed when the mismatch is corrected.
 - The applicant has completed Aadhaar authentication as per rule 10B.
 - Refund of Additional IGST on account of Upward Revision of Price subsequent to Exports:** Exporters can apply electronically for a refund of additional IGST paid due to a price increase after export, if they have already received a refund of the initial IGST. The application must be in FORM RFD-01 and will follow rule 89.
 - Transmission of export invoices to customs portal:** Invoices in GSTR-1/ GSTR-1A, will be electronically sent to the Customs portal, which will confirm the export of goods from India.
 - Processing of Refund claim:** After validating the return, the Customs PO will process the refund, & IGST amount for each shipping bill will be electronically credited to the applicant's bank account.
 - Withholding of Refund of IGST: Refund claims will be withheld if:**
 - The jurisdictional GST Commissioner requests a hold u/s 54(10)/(11).
 - The Customs PO finds the export violated the Customs Act.
 - The Commissioner believes verification of the exporter's credentials and ITC usage is needed to protect revenue.

- Transmission of refund withheld to GST officer:** If a refund is withheld u/r 96(4)(a)/(c), the claim must be submitted electronically in FORM GSTRFD-01 to the PO of CGST/SGST/UTGST. The exporter will be notified of the transmission, and the claim is deemed filed on that date.
- Transmission of refund withheld to Customs officer:** If a refund is withheld u/r 96(4)(b) for violating the Customs Act, the Customs PO will issue an order. The claim is then submitted electronically in FORM GST RFD-01 to the PO for CGST/SGST/UTGST, and the exporter will be notified. The claim is deemed filed on the transmission date.
- Refund Application Processing:** Refund applications in FORM GST RFD-01 transmitted electronically will be handled according to Rule 89.
- Refund to the Govt of Bhutan on the exports to Bhutan:** The CG may refund IGST on exports to Bhutan govt for notified goods. If refunded to Bhutan govt, the exporter is **not eligible** for an IGST refund.

- SOS:**
- Application:** Refund applications for IGST on exported services must be filed in Form GST RFD-01 and dealt as per Rule 89.

Circular no. 233/27/2024 :- If inputs were imported without paying IGST and compensation cess by availing benefits, but subsequently these taxes are paid with interest & the Bill of Entry is reassessed, then the IGST refunded on exports **will not violate** Rule 96(10).

Rule 96 B - Recovery of Refund of Unutilised ITC / IGST on export of goods, where export proceeds not realised

- Non-realisation of Exports proceeds with FEMA:** If a refund of unutilized ITC/IGST on exports is granted but sale proceeds aren't fully received within the FEMA period, the applicant must repay the refunded amount plus interest within 30 days after the period ends.
- Recovery of Amount:** If the applicant fails to repay the refunded amount, it will be recovered u/s 73 or 74, plus interest. However, if the RBI waives the requirement, the refund won't be recovered.
- Subsequent realisation of export proceeds within time frame of RBI:** If the applicant realizes the sale proceeds after the refund is recovered, they must provide evidence within 3 months. The recovered amount will be refunded up to the realized proceeds within the RBI's extended period.

Order of Refund

Sec 54(5)(7) with Rule 92	Order of Refund - If PO satisfies that claim is refundable (full/part), he may make an order in Form GST RFD-06 , & amount shall be credited to Consumer welfare fund (Paid to applicant in specified circumstances where direct refund is available).		
Rule 92(1)	<ul style="list-style-type: none"> ➤ Sanctioning of refund: The PO will issue an RFD-06 order to sanction a refund if it's due. They can credit the amount to the Consumer Welfare Fund, but if unjust enrichment doesn't apply, the refund will go directly to the applicant. ➤ Details of Refund order: The refund order will include: <ul style="list-style-type: none"> ➢ Any amount refunded provisionally ➢ Amount adjusted against outstanding demands ➢ Balance amount refundable ➤ Refund in cash & credit, based on original mode of payment: Refunds will be given in cash and as ITC, based on the original payment method: <ul style="list-style-type: none"> ➢ Cash Component: The officer will issue a refund after adjusting any outstanding demands. ➢ Credit Component: The officer will recredit the E-credit ledger as ITC. ➤ Payment order & deposition in bank a/c of recipient: <ul style="list-style-type: none"> ➢ The refund will be credited electronically to the applicant's bank account as mentioned in their registration. ➢ The refund order does not require revalidation. ➢ If the refund isn't disbursed within the same FY, revalidation is needed. ➢ The CG disburses refunds based on consolidated payment advice. 	Rule 92(2): With-holding of Refund:	<ul style="list-style-type: none"> ➤ General Withholding: If the PO believes a refund should be withheld u/s 54(10)/(11), they must inform the applicant of the reasons. ➤ Sec 54(10): If the applicant has not filed a return and there's no stay from a court, the PO may: <ul style="list-style-type: none"> ➢ Withhold the refund until the return is filed or taxes are paid. ➢ Deduct any due tax, interest, or penalties from the refund. ➤ Sec 54(11): If a refund order is under appeal, and the Commissioner believes granting it may harm revenue due to fraud or malfeasance, they may withhold the refund after hearing the applicant. ➤ Interest on Withheld Refunds: If a refund is withheld u/s 54(11), the applicant is entitled to interest at 6% p.a if the appeal results in a refund. ➤ Release of Withheld Refunds: If the PO or Commissioner finds that withholding is no longer necessary, they can issue an order to release the refund.
		Rule 93 Credit of the amt. of rejected refund claim:	<ul style="list-style-type: none"> ➤ If any deficiencies are found, the previously debited amount will be re-credited to the E-credit ledger. ➤ If a refund claim is fully or partially rejected, the rejected amount will also be re-credited by a prescribed order. ➤ A refund is considered rejected if the appeal is denied or if the claimant agrees in writing not to appeal.

Rule 95B read with Circular no. 227/21/2024: Refund of tax paid on inward supplies of goods received by Canteen Stores Department (CSD) & its Procedure:

Introduction	<ul style="list-style-type: none"> ➤ The CSD can claim 50% CGST refund on goods for Unit Run Canteens (URCs). ➤ Refund applications must be filed quarterly in FORM GST RFD-10A.
Refund Conditions	<ul style="list-style-type: none"> ➤ Goods must come from registered supplier with valid tax invoice and supplier has filed GSTR-1 & GSTR-3B. ➤ The invoice must include the CSD's name and GSTIN, and goods should be for resale to Canteens or authorized customers.
Procedure	<ul style="list-style-type: none"> ➤ CSD can file for a 50% GST refund on goods for resale in URCs or authorized customers in FORM GST RFD-10A. ➤ Claims can cover multiple quarters but must be submitted quarterly and include: <ul style="list-style-type: none"> ➢ An undertaking for resale. ➢ A declaration of no prior refunds claimed for those invoices. ➤ Claims can be filed within two years of receiving the goods. ➤ The PO will verify GSTR-1 and GSTR-3B filings and invoice accuracy. ➤ Refunds are capped at 50% of CGST, SGST, UTGST, and IGST paid. ➤ After review, the officer will issue an order (RFD-06). ➤ Manually submitted applications will follow previous guidelines.

Sec 56 :- Interest on Delayed Refunds

Situations	Refund is not paid	Interest	Interest is Payable
If order passed by PO u/s 54(5)	within 60 days , from date of receipt of application from applicant	6% p.a.	from 61 th days till the date of payment of refund
order passed in an appeal /further proceedings	Within 60 days from date of receipt of application filed consequent to such order till the date of refund	9% p.a.	from 61 th days till the date of payment of refund

Circular 79/53/2018

- For above limit of 60 days in calculation of interest, All tax authorities are advised to issue final sanction orders (RFD-06) within 45 days from date of generation of ARN, so that disbursement completed within 60 days by both Central/state authorities, to save interest.

Period of delay shall not include [Rule 94(2)]

- a) time taken to furnish reply or additional document **beyond 15 days** of receipt of notice &
- b) time taken by applicant to give correct bank account details for crediting refund or for validating such details.

Mechanism for refund of additional IGST paid on account of upward revision in price of goods subsequent to exports (Cir. no. 226/20/2024):-

- Exporters must pay additional IGST for upward price revisions on exported goods.
- Refunds for this additional IGST can now be claimed using FORM GST RFD-01, processed by the jurisdictional GST officer.
- Exporters must upload relevant documents, including statements 9A and 9B.
- GSTN will provide shipping bill details to aid in processing.
- Refunds are not available for claims below ₹1000 and must be submitted within 2 years.
- Required documents include shipping bills, invoices, contracts, proof of additional IGST payment, and a CA or CMA certificate.
- The officer will verify details from the exporter's GSTR-1 and GSTR-3B.
- If eligible, a refund sanction order will be issued.
- For downward price revisions, excess IGST must be returned with interest, and the officer will confirm proper deposit.

V'Smart Academy



V'Smart Academy

